

STANDARD CONSTRUCTION

FRAME: 18-GA. galvanized steel, channel or flanged type.

BLADE: 18-GA. galvanized steel. Blades approximately 2⅜" on centers.

SCREEN: (When indicated)

½" sq. mesh, 19-GA. galvanized steel (.041").

CONSTRUCTION: Riveted and/or welded for maximum service.

OPTIONS

Frames and Blades of other gauges

Other materials - Stainless steel, Copper, Aluminum, etc.

Finishes - Enamels, Epoxies, etc.

Screens - Insect screen ⅜" aluminum mesh,

-or- ½" flattened aluminum, .051",

-or- ¼" sq. mesh, 18-GA galvanized steel, .047",

-or- ½" sq. mesh, 18-GA stainless steel, .047",

Others available.

NOTES

- Nominal deductions will be made to the opening size given.
- Approximate shipping weight is 5.5 lbs./sq.ft.

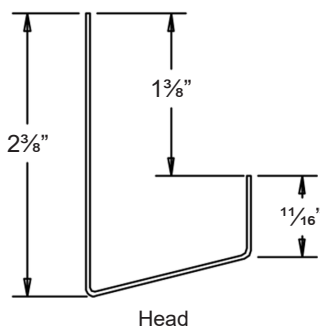
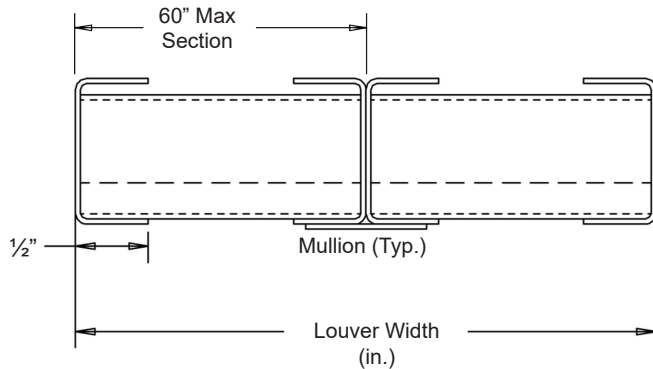
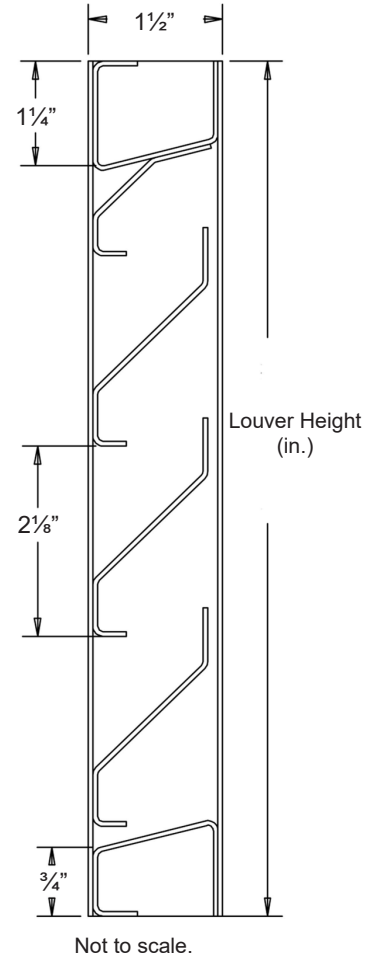

Flange Frame Available

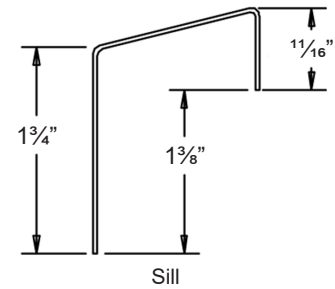
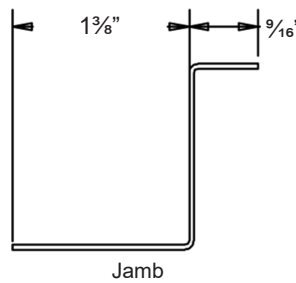

Item #	Qty	Width	Height	Width	Height	Mullion	Type	Location	Union Made
		Opening Size		Louver Size			Screens		
Arch. / Eng. :						EDR:		ECN:	Job:
Contractor:									
Project:						Date:		DWN:	DWG:

In the interest of product development, Louvers & Dampers reserves the right to make changes without notice.